



Standard Features

- HSS Structural Tubing Frame, Floor, Wall, Roof
- Cambered Radius Roof Bows
- Aluminum Extrusion Trim Top And Bottom
- Screwless VHB Bonded Painted Aluminum Exterior Panels
- Fully Enclosed Wiring
- Led Exterior And Interior Lights
- One-Piece Aluminum Roof
- 4' Aluminum Barlocks
- Side Vent
- Zinc Coated Hardware

Specifications

| | | | |
|-----------------------|------------------------------|-----------------------|-----------------------|
| Axle: | (2) 5,200 lb. Lippert Spring | Crossmember: | Steel HSS 2.0" X 2.0" |
| Brakes: | Electric Self-Adjusting | Floor: | 3/4" Plywood |
| Coupler: | 21,000 lb. Demco Adjustable | Walls: | 3/8" Plywood |
| Jack: | 5,000 lb. Top-Wind | Wheels: | 225/75R15 D Steel |
| Side Door: | 36" x 72" with RV Latch | Electric Plug: | 7 Wire RV |
| Floor D-Rings: | 4,080 lb. | Ramp Rating: | 2,500 lb. Midspan |
| Main Rails: | Steel HSS 6.0" X 2.0" | | |

Options

| Rear Door | |
|-----------|------------|
| Ramp | Barn Style |

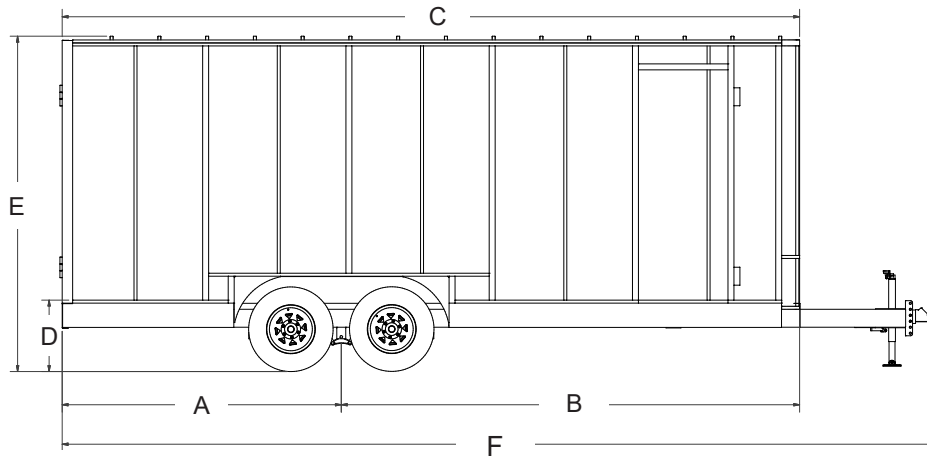

Dimensions

| Model | A | B | C | D | E | F |
|-----------------|----------|------------|-----------|----------|----------|----------|
| LARCT52-820F-78 | 93 1/2" | 153 1/2" | 247" | 21.6875" | 104 1/8" | 292 5/8" |
| LARCT52-820F-86 | 93 1/2" | 153 1/2" | 247" | 21.6875" | 112 1/8" | 292 5/8" |
| LARCT52-824F-78 | 113 1/2" | 181 1/2" | 295" | 21.6875" | 104 1/8" | 340 5/8" |
| LARCT52-824F-86 | 113 1/2" | 181 1/2" | 295" | 21.6875" | 112 1/8" | 340 5/8" |
| LARCT52-822V-78 | 93 1/2" | 170 11/16" | 264 3/16" | 21.6875" | 104 1/8" | 292 5/8" |
| LARCT52-822V-86 | 93 1/2" | 170 11/16" | 264 3/16" | 21.6875" | 112 1/8" | 292 5/8" |
| LARCT52-826V-78 | 113 1/2" | 198 11/16" | 312 3/16" | 21.6875" | 104 1/8" | 340 5/8" |
| LARCT52-826V-86 | 113 1/2" | 198 11/16" | 312 3/16" | 21.6875" | 112 1/8" | 340 5/8" |

| Model | Rear Door Entrance | Space Between Fenders |
|-----------------|--|-----------------------|
| LARCT52-820F-78 | 87 1/8"W X 72 11/16"H BARN 87 1/8"W X 74 11/16"H RAMP | 81" |
| LARCT52-820F-86 | 87 1/8"W X 80 11/16"H BARN 87 1/8"W X 82 11/16"H RAMP | 81" |
| LARCT52-824F-78 | 87 1/8"W X 72 11/16"H BARN 87 1/8"W X 74 11/16"H RAMP | 81" |
| LARCT52-824F-86 | 87 1/8"W X 80 11/16"H BARN 87 1/8"W X 82 11/16"H RAMP | 81" |
| LARCT52-822V-78 | 87 1/8"W X 72 11/16"H BARN 87 1/8"W X 74 11/16"H RAMP | 81" |
| LARCT52-822V-86 | 87 1/8" W X 80 11/16"H BARN 87 1/8"W X 82 11/16"H RAMP | 81" |
| LARCT52-826V-78 | 87 1/8"W X 72 11/16"H BARN 87 1/8"W X 74 11/16"H RAMP | 81" |
| LARCT52-826V-86 | 87 1/8"W X 80 11/16"H BARN 87 1/8"W X 82 11/16"H RAMP | 81" |

| Model | Description | Net Weight | GVWR | Payload Cap. |
|-----------------|---|------------|------------|--------------|
| LARCT52-820F-78 | 8' x 20' x 78" wall height, 5,200 lb. Tandem Axle Flat Nose | 3,073 lb. | 11,400 lb. | 8,327 lb. |
| LARCT52-820F-86 | 8' x 20' x 86" wall height, 5,200 lb. Tandem Axle Flat Nose | 3,183 lb. | 11,400 lb. | 8,217 lb. |
| LARCT52-824F-78 | 8' x 24' x 78" wall height, 5,200 lb. Tandem Axle Flat Nose | 3,669 lb. | 11,400 lb. | 7,731 lb. |
| LARCT52-824F-86 | 8' x 24' x 86" wall height, 5,200 lb. Tandem Axle Flat Nose | 3,779 lb. | 11,400 lb. | 7,621 lb. |
| LARCT52-822V-78 | 8' x 22' x 78" wall height, 5,200 lb. Tandem Axle V-Nose | 3,304 lb. | 11,400 lb. | 8,096 lb. |
| LARCT52-822V-86 | 8' x 22' x 86" wall height, 5,200 lb. Tandem Axle V-Nose | 3,403 lb. | 11,400 lb. | 7,997 lb. |
| LARCT52-826V-78 | 8' x 26' x 78" wall height, 5,200 lb. Tandem Axle V-Nose | 3,940 lb. | 11,400 lb. | 7,460 lb. |
| LARCT52-826V-86 | 8' x 26' x 86" wall height, 5,200 lb. Tandem Axle V-Nose | 4,050 lb. | 11,400 lb. | 7,350 lb. |



Specs are subject to change without notice. Please contact Southland Trailer Corp Product Specialist for price confirmation on all Products. - Revised January 2025